



Typical Applications

- Weather awareness
- Aviation industry
- Agronomy
- Hydrometeorology
- Military meteorology
- Maritime meteorology
- Extend wireless communication range by relaying data between SenSpot™ and SeniMax™ when the RF link is weak (as repeater)

Benefits

- **Long lifetime**
- **Wireless transmission:** No wiring is required for data collection
- **Lightweight**
 - Wireless transceiver: 120 g (4.2 oz)
 - Weather station transmitter: 0.7kg (1.5lb)
 - Solar panel: 100 g (3.5oz)
- **Easy mounting:** Flange mount or adhesive tape
- **Ingress Protection:** IP65, weatherproof and protected against rain, snow, and UV exposure
- **Maintenance free:** No battery replacement, calibration or post-installation maintenance is required

Specifications

- **Wind Speed:**
 - Range: 0–70 m/s (156mph)
 - Resolution: 0.01 m/s
 - Accuracy: $\pm 2\%$ or 0.3 m/s (0–30m/s), $\pm 3\%$ (30 – 70 m/s)
- **Wind Direction:**
 - Azimuth Range: 0-360°
 - Resolution: 0.1°
 - Accuracy: $\pm 2^\circ$
- **Temperature:**
 - Range: -40 to +60°C
 - Resolution: 0.1°C
 - Accuracy: $\pm 0.3^\circ\text{C}$ (-20 to +50°C), $\pm 0.7^\circ$ (other)
- **Relative Humidity:**
 - Range: 0–100%
 - Resolution: 0.1%
 - Accuracy: $\pm 2\%$ (5-95%)
- **Atmospheric Pressure:**
 - Range: 500–1100 hPa
 - Resolution: 0.1 hPa
 - Accuracy: ± 0.3 hPa (0 to +60°C), ± 1.0 hPa (-40 to 0°C)
- **Working temperature:** -40°C to +65°C (-40°F to +150°F)
- **Wireless communication range:** 1.0km (0.62mi) free space
- **Customizable cable length:** 0.3m (1ft) to 4m (12ft)
- **Weather Station Transmitter Dimension:** 30 cm high x 13 cm wide
- **Transceiver Box Dimension:** 140mm (5.50") x 105mm (4.12") x 62mm (2.44")

Description

SenSpot™ wireless weather station provides an easy way to install a scalable solution for measuring key meteorological variables including wind speed and direction, atmospheric pressure, temperature, humidity. It comes with high-capacity lithium-ion battery and solar panel and its mount. As a result, it does not require battery replacement and once installed, it is almost maintenance free. The whole product has IP65 protection (completely weatherproof) thus, it is an excellent choice for meteorological instrumentation applications that require the sensors to be installed some outdoor and often hard to access places.

It uses model 92000 weather transmitter from R.M YOUNG that is one of the industry leaders in meteorological instrumentation.

This product uses Resensys's proprietary Active RF Technology, just the same as other products of Resensys. Resensys SenSpot™ technology offers a high-performance method for large-scale sensing, wireless synchronization and ultra-energy efficient wireless communication.

It can also serve as SenSpot™ repeater at the same time to extend the wireless communication range between SenSpot™ and SeniMax™.

For more detailed information about the weather station, please see the product datasheet which can be found from:

<https://www.youngusa.com/wp-content/uploads/2016/12/92000-90H.pdf>

Installation

Wireless transceiver box comes with mounting flanges. It can be installed either with screws and anchors through the flange holes or with VHB adhesive tape (for steel and smooth surfaces).

Wireless Transceiver Dimension

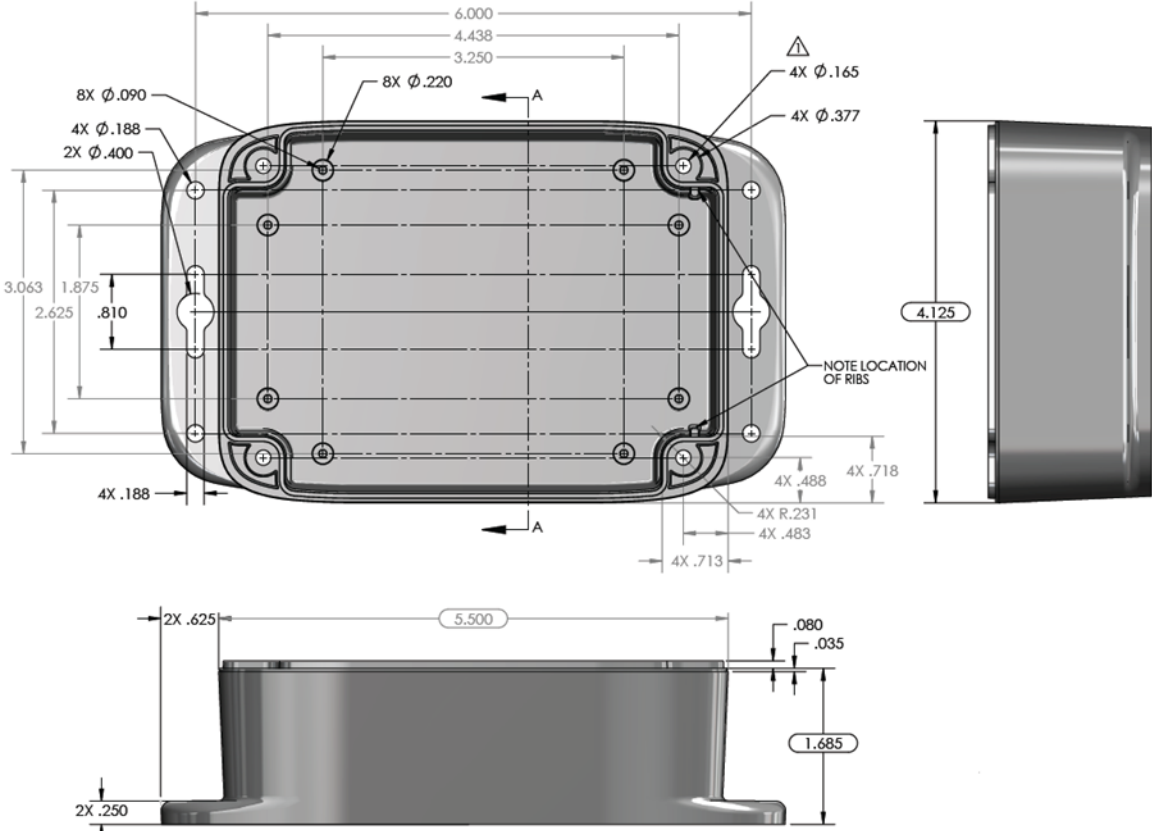

Figure 1: Wireless transceiver dimensions for weather station. All dimensions are in inch.