

Typical Applications

- Bridge health monitoring
- General structural integrity monitoring (buildings, dams, tunnels, levies, etc.)

Features & Benefits

- **Long lifetime** (battery life of 10 years)
- **Wireless communication** (IEEE 802.15.4)
- **Lightweight**, about 120 grams
- **Easy mounting**
 - Self-adhesive, no drilling is required (e.g. steel)
 - Flange-mount, drilling is required (e.g. concrete)
- **Quick installation**, 1-2 minutes
- **Adjustable sampling interval**: 0-100 samples per second
- **Adjustable sensitivity threshold**: From 8mg to 255mg. Threshold can also be set adaptive to limit number of events
- **Adjustable Transmitting interval**
- **Full range**: $\pm 2g$ ("g" is the acceleration of gravity)
- **Resolution**: 4 μg
- **Noise Level**: X & Y & Z Direction: $25 \mu g / \sqrt{Hz}$
- **Working temperature**: $-40^{\circ}C$ to $+65^{\circ}C$ (-40 to $+150^{\circ}F$)
- **Shock survival**: 1000g, 0.1s, no damage to the electronics
- **Long communication range**: 1.0km free space
- **Small size**: 50mm (1.96") x 50mm (1.96") x 34mm (1.34")

- **Power source**: replaceable lithium-ion battery



Description

SenSpot™ provides an easy to install, scalable solution for distributed structural integrity monitoring. SenSpot™ vibration uses Resensys's proprietary Active RF Technology, similar to other SenSpot™ in its family. Resensys ART technology offers a high performance method for large-scale sensing, synchronization, and ultra-energy efficient wireless communication.

SenSpot™ is designed to operate maintenance-free for decades. After installation, SenSpot™ does not need calibration, battery replacement, or any other maintenance during its entire service life. Due to small size and lightweight, adhesive-mount SenSpot™ sensors can be applied easily to as many critical spots on a structure as needed, with minimal installation effort. SenSpot™ vibration can be used on different elements of a structure to monitor vibration.

Dimensions

Vibration SenSpot comes in either self-adhesive or flange-mount form factors. A general diagram of this unit is shown below.

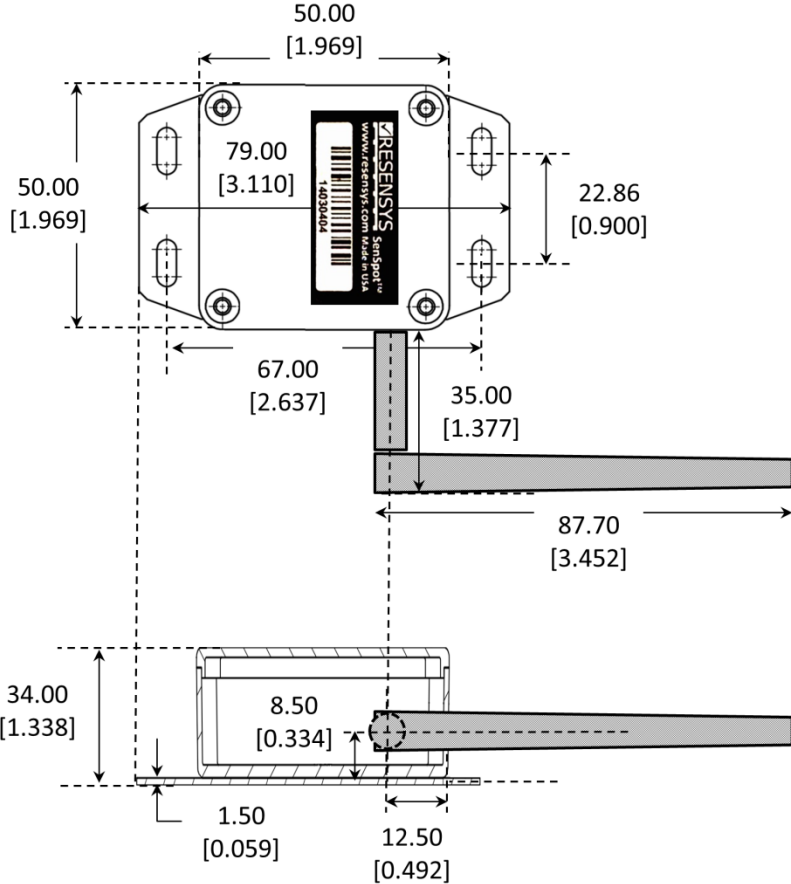

All dimensions are in mm [inch].

Direction Diagram

For SenSpot™ Wireless 1D Vibration, **ONLY** the acceleration in the Z direction is measured.

