

## Typical Applications

- Levee integrity monitoring

## Features & Benefits

- **Long lifetime:** battery life of 10 years
- **Multi-channel synchronized sensing:** Up to 4 channels
- **Wireless communication:** IEEE 802.15.4
- **Lightweight**
  - Wireless transmitter: 200 g (7.1 oz.)
  - Wire loop sensing probes: typical 4 x custom lengths up to several miles):
- **Adjustable sampling interval:** from 4 readings per second, to 10 readings per hour
- **Working temperature:** -40°C to +65°C (-40°F to +150°F)
- **Long communication range:** 1.0km (0.62mi) free space
- **Customizable probe length:** up to several miles/km
- **Ingress Protection:** IP65, weatherproof and protected against rain, snow, and UV exposure
- **Small size:**
  - Wireless transmitter: 140.21mm (5.52") x 60.5mm (2.382") x 32.5mm (1.28")
- **Power source:** replaceable lithium-ion battery

## Description

The SenSpot™ Wireless 4-Channel Levee Integrity Sensor can be used to monitor the structural integrity of a levee. The principle is simple: a wire loop is connected to each channel and is further installed on to the levee at its top location. The wire loop can be customized to the length of the levee



and it can be up to several miles if needed. The attachment uses small anchors every 10-20 feet to keep the wire secured to the levee. When any monitored location of the levee experiences overflow or structural damage, the wire loop also breaks. The loop is designed to withstand environmental conditions and elements, and at the same time, it is designed to break in presence of water flow. The difference of the resistance (continuity) of the wire will be detected by the wireless sensor and triggers an immediate notification alert. Such notifications are sent automatically via emails or text message to authorities so they can take necessary actions. Each SenSpot™ has the capability to be connected to multiple wire loops, which can be used to monitor different sections or levee, or they can be used to provide redundancy (e.g., using two wire loops to monitor each section).

Resensys SenSpot™ sensors are designed to operate maintenance-free for more than a decade. After installation, SenSpot™ sensors do not need calibration, battery replacement, or any other maintenance for at least 10 years. Due to the small size and light weight, SenSpot™ sensors can be applied easily to as many critical spots on a structure as needed, with minimal installation effort.

# Wireless Transmitter Dimensions

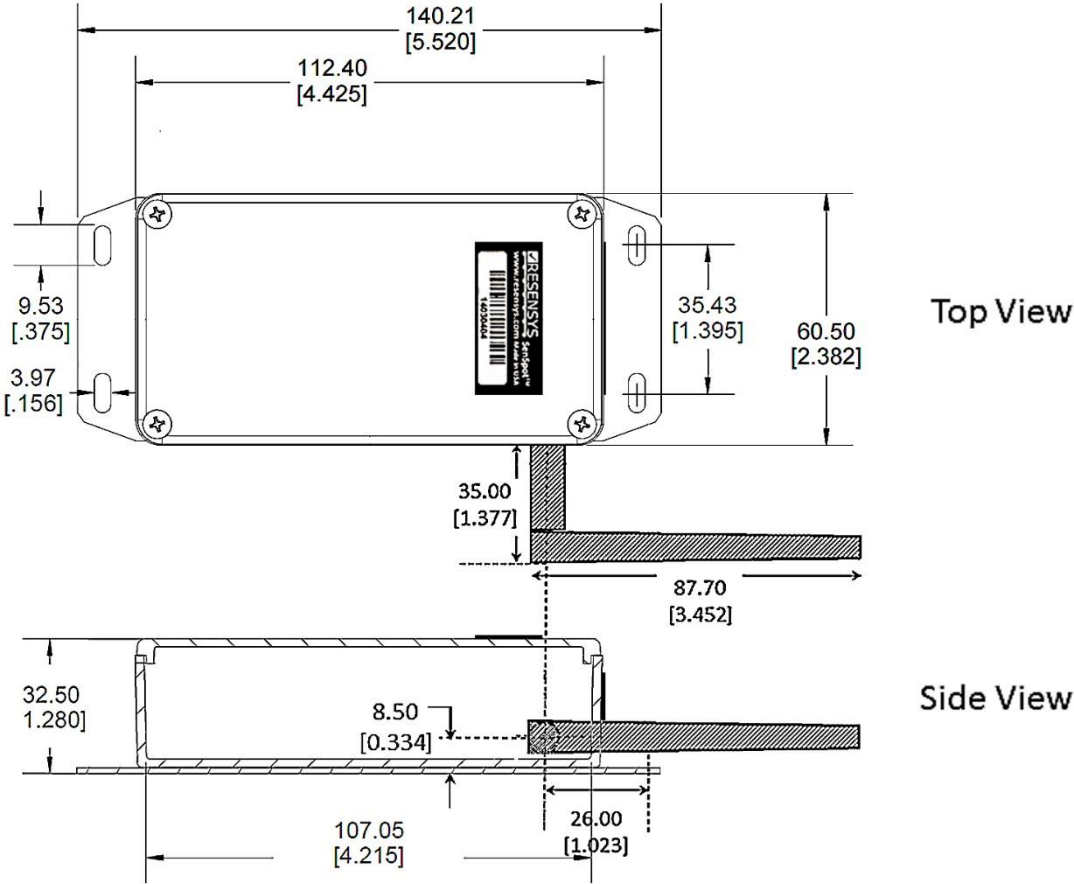

Figure 1: Dimensions of the SenSpot™ 4-Channel Temperature Sensor, all dimensions are in mm [inch]

## Sample Application Diagram

The following diagram (Figure 2) shows a typical application of the 4-Channel levee integrity monitoring sensor.

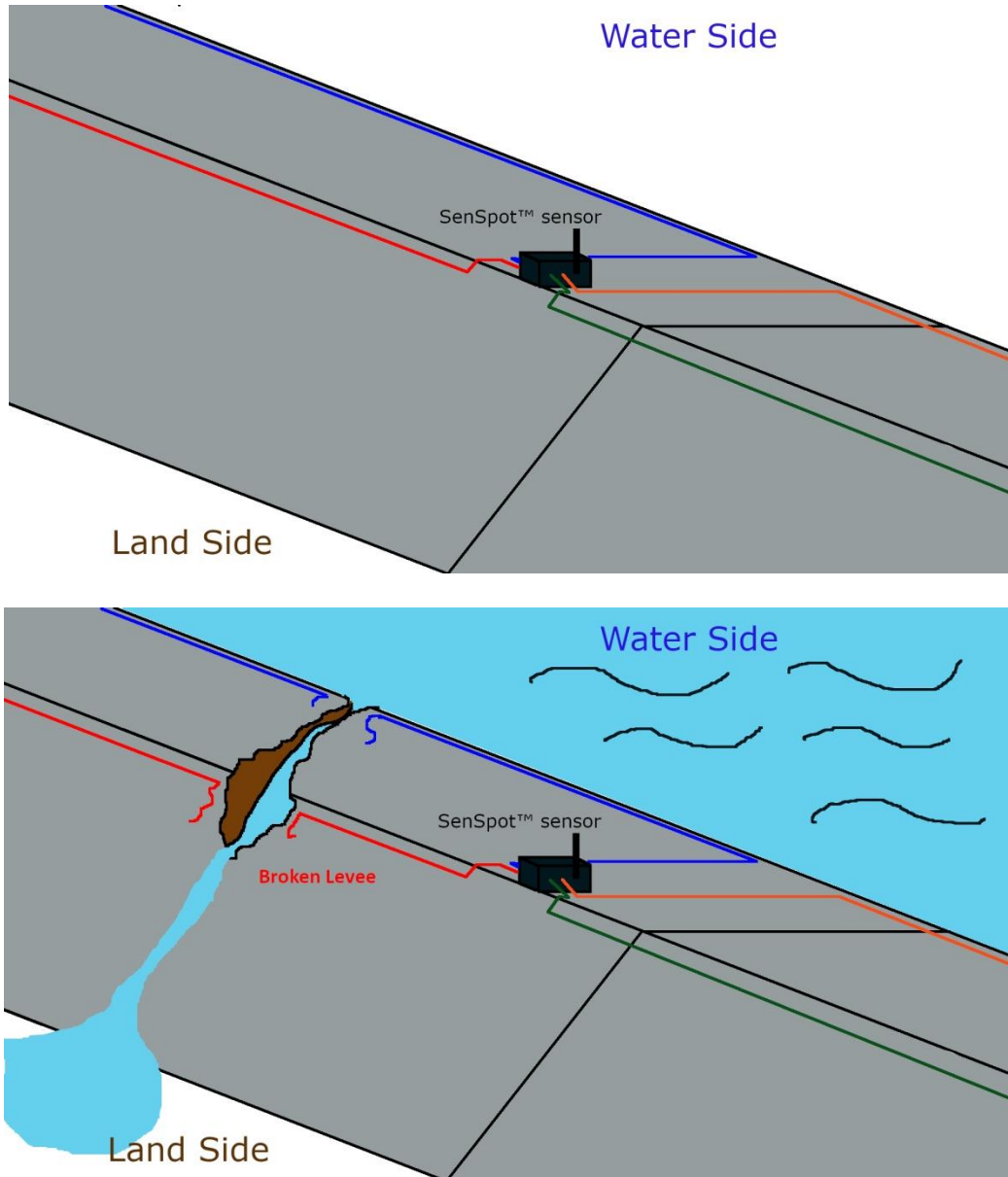

Figure 2: Schematic view of a levee for a typical application of the 4-Channel levee integrity monitoring sensor

As shown in Figure 2, each channel of wireless SenSpot is connected to a wire loop. Once any of the 4 wire loops breaks (e.g., the red one in the bottom figure), the resistance of the wire increases from a small number to infinity. The sensor detects this change and triggers an alert. Email notification will be sent out so that further actions can be taken.

# Example pictures of a deployed device



**Wire installed on the along the length of Levee at its top location.**

Figure 3: Example pictures of a deployed device/sensor for a levee